

Special-purpose Machines



**Design
Supply
Service**



Special-purpose Machines

MWE designs, manufactures and supplies special-purpose machines of the rolling mill and metallurgical industry for a wide variety of different applications. In close cooperation with you, we find technical solutions which meet the local conditions on-site and which correspond to the latest state-of-the-art techniques and to the special requirements of the necessary technology. The machines and equipment will be erected and commissioned by us on-site.

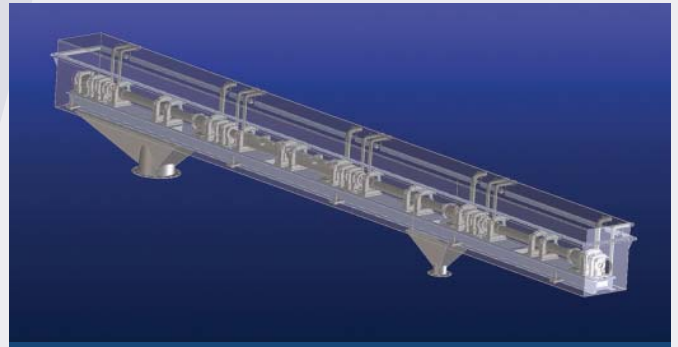

Cooling line for steel bar stock, installed inside of a bypass (Loop) with loop controller

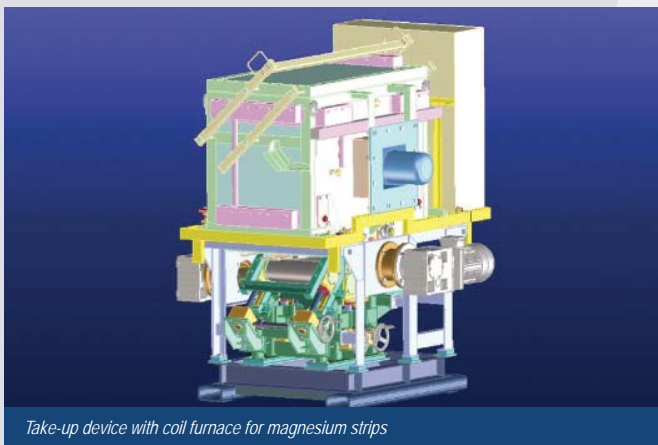

Take-up device with coil furnace for magnesium strips

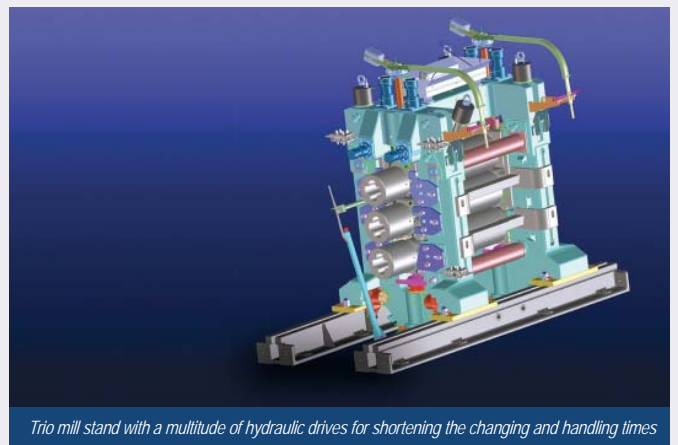

Trio mill stand with a multitude of hydraulic drives for shortening the changing and handling times

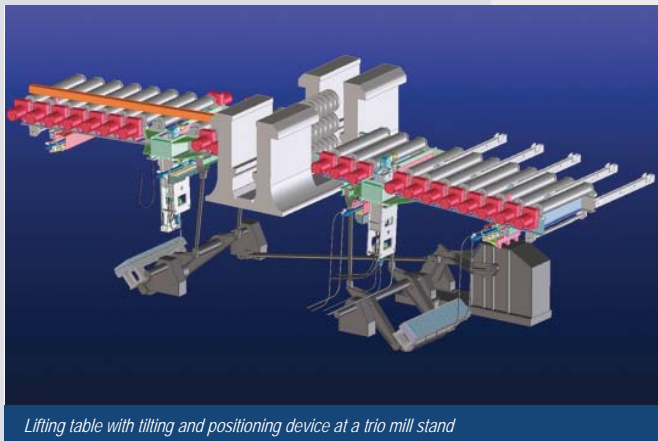

Lifting table with tilting and positioning device at a trio mill stand

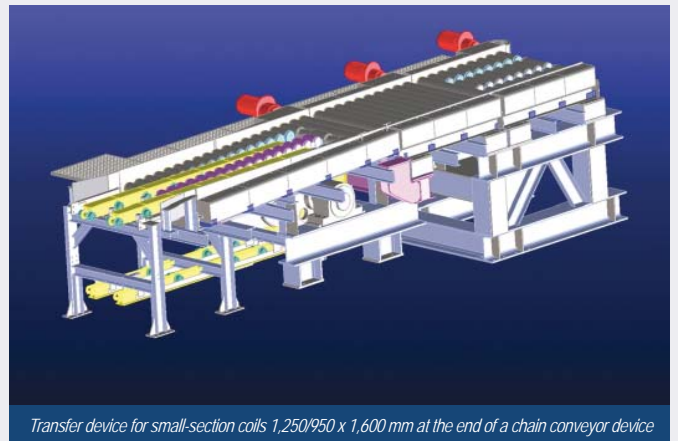

Transfer device for small-section coils 1,250/950 x 1,600 mm at the end of a chain conveyor device